

# 9-10 t G系列 蓄电池平衡重式叉车 G series battery powered counterbalanced forklift truck



- > **高可靠稳定性：**成熟可靠、性能卓越的原装进口核心部件；免维护的湿式制动
- > **主动安全：**故障主动降速停车并驻车；弯道智能限速；驾驶员存在感应系统
- > **高效与节能：**更适合狭窄空间的小型车身；自动驻车；蓄电池横向侧铲，操作更加简单；节能型液压系统；电液复合制动；全液压同步转向系统；基于多点温度智能控制的循环冷却系统
- > **舒适：**进口静音齿轮泵；全悬浮座椅；极佳的前方和后方视野
- > **维护便捷：**蓄电池自动补水；互锁式车辆快捷充电接口

- > **High reliability and stability** Mature and reliable, excellent performance of imported core components; Maintenance free wet braking.
- > **Active safety** Active slowing down, braking and parking in faulty; Intelligent speed-limiting when turning; OPS system.
- > **High efficiency and energy-saving** Small body more suitable for narrow space; Auto hold; Battery lateral-side shoveling, easier to operate ;Energy-saving type hydraulic system. Electric-hydraulic braking; Fully hydraulic steering systems with Electronic Follow Up unit; Cycle cooling system based on intelligent multi point temperature control.
- > **Comfortable** Imported silent gear pump; Fully suspension operator's seat; Excellent front and rear view.
- > **Maintenance conveniency** Automatic water replenishment battery; Interlocking vehicle fast charging interface.

**HELI**  
中国合力 提升未来

**G series** / 智能·环保 INTELLIGENT  
ENVIRONMENT-FRIENDLY



# G 9-10t 蓄电池平衡重式叉车

G series battery powered counterbalanced forklift truck

## 制造商和技术参数 Manufacturer's Data and Design Characteristics

特性		character				HELI	
1.01	制造商	manufacturer					
1.02	型号	model				CPD100	CPD90
1.03	配置号	configuration number				GA2	GA2
1.04	额定起重量	rated capacity	Q	kg	10000	9000	
1.05	载荷中心距	load center distance	c	mm	600	900	
1.06	动力方式	power mode				蓄电池 battery	
1.07	驾驶方式	driving mode				乘座式 seated	
1.08	轴距	wheel base	L1	mm	2580	2580	
轮胎		tyre					
2.01	轮胎类型	tyre type				实心胎 solid tyre	
2.02	轮胎数量 (前/后)	wheel number (front/rear)				4 × /2	
2.03	轮距 (前/后)	wheel base (front/rear)		W3/W4	mm	1636/1524	
2.04	轮胎 (前/后)	tyre (front/rear)				8.25-15/250-15	
尺寸		size					
3.01	前悬距	front overhang	L2	mm	660	660	
3.02	门架倾角 (前/后)	mast tilt angle (front/rear)	$\alpha/\beta$	°	6/9	6/9	
3.03	最大起升高度	Max.lifting height	H	mm	3000	3000	
3.04	护顶架高度	overhead guard height	H4	mm	2445	2445	
3.05	货叉尺寸 (厚 × 宽 × 长)	fork size (thickness × width × length)	T × W × L4	mm	80 × 175 × 1220		85 × 175 × 1820
3.06	车体长度 (不含货叉)	truck body length (fork excluded)	L'	mm	3760	3760	
3.07	车体宽度	truck body width	W2	mm	2116	2116	
3.08	转弯半径	turing radius	r	mm	3320	3320	
3.09	门架处离地间隙(满/空载)	clearance between mast and ground (loaded/unloaded)	H5	mm	130/150	130/150	
3.10	轴距中心离地间隙(满/空载)	clearance between wheel base center and ground(loaded/unloaded)	H6	mm	170/180	170/180	
3.11	直角堆垛通道宽度 (托盘1200 × 1200mm, 间隙200mm)	right angle stacking aisle width (pallet1200 × 1200mm, clearance200mm)	Ast	mm	5380	-	
	直角堆垛通道宽度 (托盘1800 × 1800mm, 间隙200mm)	right angle stacking aisle width (pallet1800 × 1800mm, clearance200mm)	Ast	mm	-	5980	
性能		performance					
4.01	行驶速度 (满/空载)	travelling speed (loaded/unloaded)		km/h	13/15	13/15	
4.02	起升速度 (满/空载)	lifting speed (loaded/unloaded)		m/s	0.22/0.35	0.22/0.35	
4.02	下降速度 (满/空载)	lowering speed (loaded/unloaded)		m/s	0.38/0.3	0.38/0.3	
4.03	最大爬坡能力 (满载)	gradeability (loaded)		%	15	15	
4.04	最大牵引力 (满载)	Max.traction force (loaded)		kN	50	50	
电机和控制器		motor and controller					
5.01	驱动电机功率 (S2-60min)	driving motor power (S2-60min)		kW	AC 17 × 2	AC 17 × 2	
5.02	起升电机功率 (S3-15%)	lifting motor power (S3-15%)		kW	AC 26.5 × 2	AC 26.5 × 2	
5.03	制动电机功率 (S3-15%)	braking motor power (S3-15%)		kW	AC 5	AC 5	
5.04	驱动电机控制方式	drive motor controlling mode			MOS管/交流 MOSFET/AC	MOS管/交流 MOSFET/AC	
5.05	起升电机控制方式	lifting motor controlling mode			MOS管/交流 MOSFET/AC	MOS管/交流 MOSFET/AC	
5.06	制动电机控制方式	braking motor controlling mode			MOS管/交流 MOSFET/AC	MOS管/交流 MOSFET/AC	
重量		weight					
6.01	总重 (包含/不包含蓄电池)	total weight (with/without battery)		kg	13200/9880	13900/10580	
电池		battery					
7.01	蓄电池电压/容量K <sub>s</sub>	battery voltage/capacity K <sub>s</sub>		V/Ah	80/1240-1550	80/1240-1550	

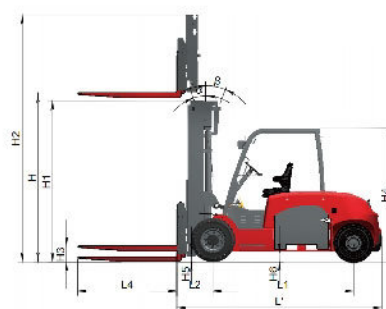
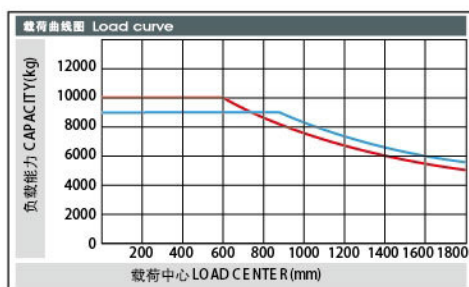

Ast: 直角堆垛通道宽度 Right angle stacking aisle width

a: 间隙 Clearance

b: 载荷长度 Load Length

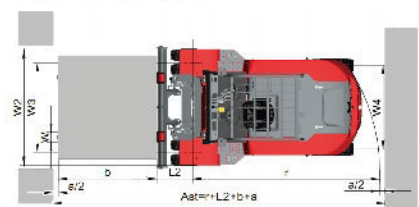

**HELI** 安徽合力股份有限公司  
ANHUI HELI CO., LTD.

地址: 中国合肥经开区方兴大道668号  
电话: (86 551)63632133, 63648005, 63689000  
传真: (86 551)63633431  
服务: 4001-600761  
网址: <http://www.helichina.com>

ADD:NO.668 Fangxing Street, Economical Development Zone, Hefei ,P.R.China  
TEL:(86 551)63632133,63648005,63689000  
FAX:(86 551)63633431  
400 SERVICE: 4001-600761  
WEBSITE:<http://www.helichina.com>

授权经销商 AUTHORIZED DEALER

\* 本公司保留更改产品设计和规格的权力, 恕不另行通知。  
\* Our products are subject to improvements and changes without notice.